

Vol.770-Pg.1275
 Orig - 47.72 acres
 Pt. Split "A" - 2.02 acres
 Rem - 45.70 acres

ANNA GASCOIGNE
 Vol.770-Pg.1273
 Orig - 37.01 acres
 Pt. Split "A" - 4.13 acres
 Rem - 32.88 acres

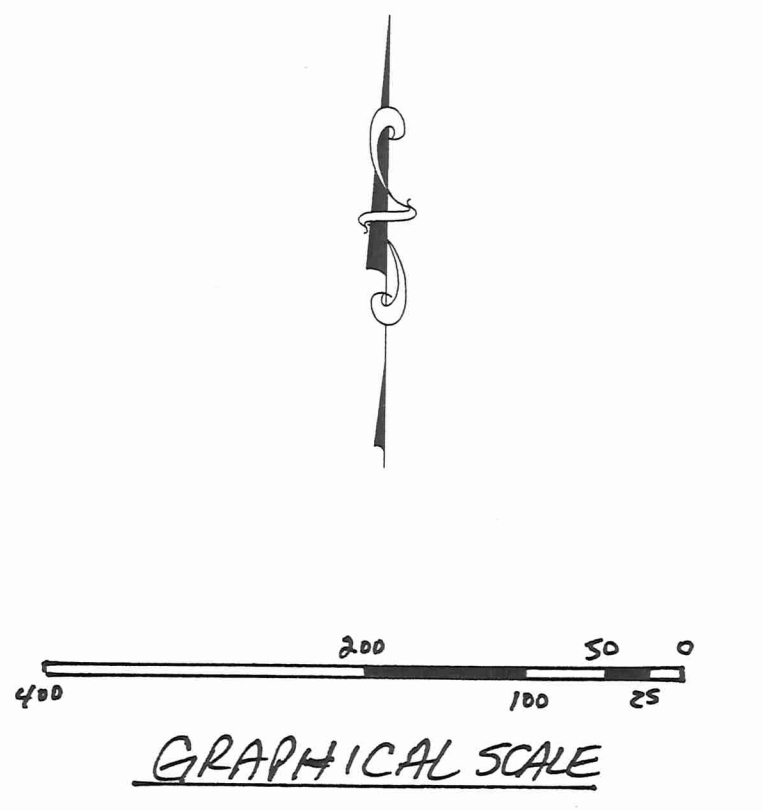

I HEREBY CERTIFY:
 This map was prepared and the premises surveyed in accordance with chapter 4733-37 of the Ohio Administrative Code.

SURVEY PLAT & LEGAL DESCRIPTION
 APPROVED PER R.C. 315.251
 R.S. 3/21/2000
 OFFICE OF THE REVISOR
 GEauga COUNTY ENGINEER



REV NO.	DESCRIPTION	DATE	BY	CHK'D
1	REVISIONS PER GEauga COUNTY ENGINEER	3-16-00	HT	HT

bj BABCOCK, JONES AND ASSOCIATES, INC
 CIVIL ENGINEERS - SURVEYORS - LAND PLANNERS
 PAINESVILLE OHIO 44077

DATE 3/7/00
 DESIGN BY H.J.
 DRAWN BY T.R.
 APPROVED BY H.J.

PLAT OF SURVEY FOR
 SCOTT BONCHA
 LOT No. 21 - TRACT ONE
 CHARDON TOWNSHIP GEauga COUNTY

SCALE: 1"=120'
 JOB NO 00-026
 SHEET 1 OF 1

